

VP SERIES VECTORPAD

Directional Keypad

FEATURES

- Discrete output directional keypad
- Rear-panel mount
- Molex PicoBlade™ connector
- Overall size: 1.6 in. (41 mm) square
- IP67 rating (button side when mounted)
- Long life: 1,000,000 cycles per key
- Construction: High strength silicone rubber over FR-4 printed circuit board
- Operating temp: -50 °C to +85 °C
- NVIS backlight, custom legends and configurations available



ASSEMBLY DIMENSIONS in inches [and millimeters]

Dimension illustrations not to scale

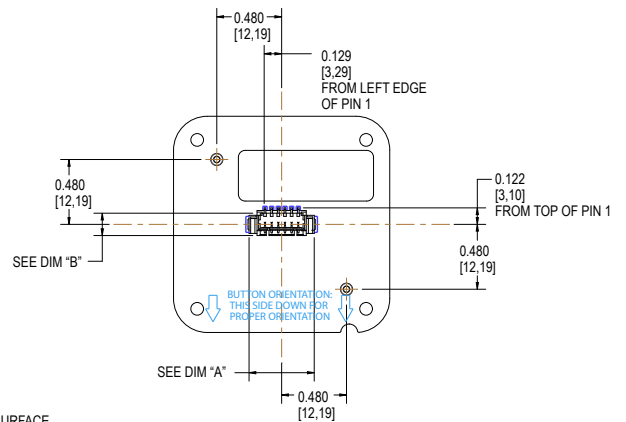
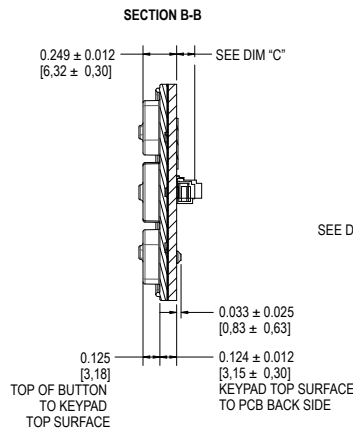
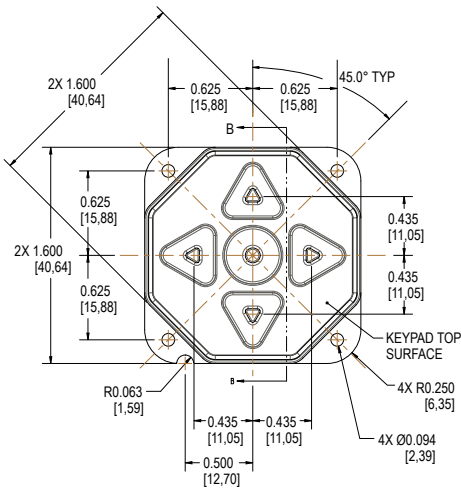

4x Button Detail

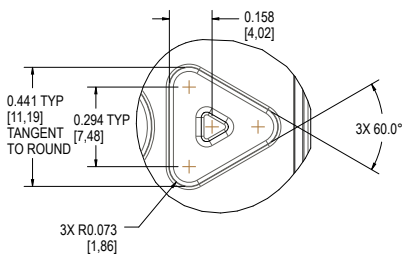

Note: Tolerance ± 0.005" [0.127 mm] unless otherwise stated

Mating Connector

PicoBlade™ PCB Headers

- 1.25 mm Pitch, 6-Position**
1. Right Angle (90°) Header Molex (PN: 532610671)
- Type: SMT, single row, right angle, 6-position
 2. Vertical Header Molex (PN: 533980671)
- Type: SMT, single row, vertical, 6-position

Recommended Mating Connector

Molex PicoBlade™ Receptacle Crimp Housing, 1.25 mm pitch, Single Row, Friction Lock, 6 Circuits (PN: 510210600)

Connector Chart

| Connector | Dimension | | | | | |
|--|-----------|-------|-------|-----|-------|-----|
| | A | | B | | C | |
| | IN | MM | IN | MM | IN | MM |
| PicoBlade™ Vertical (53398-0671) | 0.481 | 12.25 | 0.145 | 3.7 | 0.185 | 4.7 |
| PicoBlade™ 90 Right Angle (53261-0671) | 0.481 | 12.25 | 0.165 | 4.2 | 0.134 | 3.4 |

SUGGESTED PANEL DIMENSIONS in inches [and millimeters]

Panel Outside View

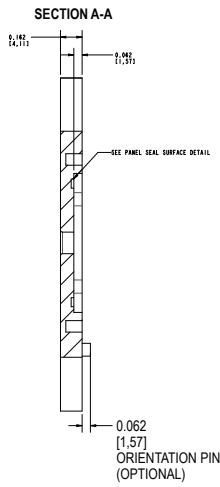
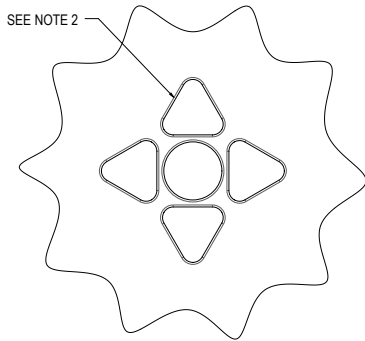

Panel Inside View

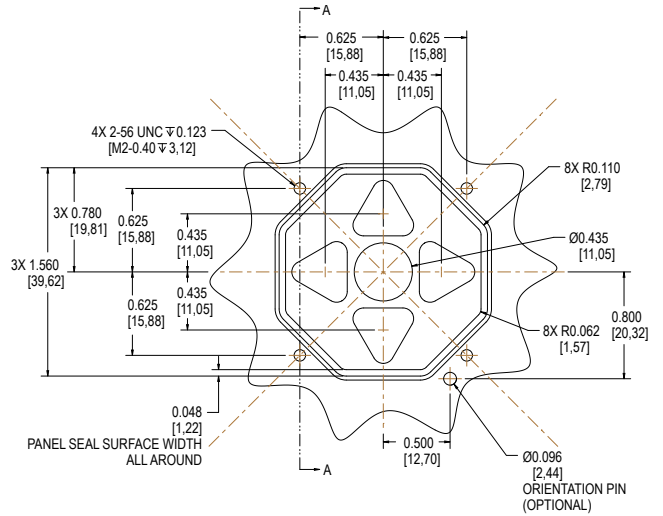

Notes:

1. Tolerance $\pm 0.005"$ [0.127 mm] unless otherwise stated
2. An edge break or round is recommended for the button openings. This is to prevent damage to the rubber caused by friction between the rubber and panel with repeated actuations.

Panel Seal Surface Detail

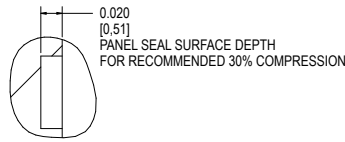

4x Button Cut-Out Detail

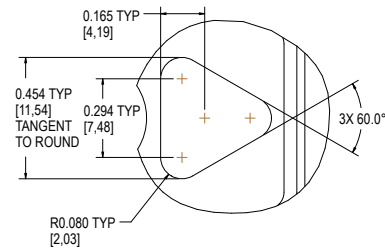

MOUNTING EXAMPLE



Mounting Recommendations

| | |
|--------------------------------------|---|
| Mounting Method | Screw-mounted through designated mounting holes in the PCB (washer and thread locker recommended) |
| Recommended Screw | Imperial: 2-56 Pan Head, 5/32" length (no washer) Metric: M2 Pan Head, 4 mm length (no washer) |
| Recommended Fastener Material | Stainless steel or corrosion-resistant equivalent |
| Recommended Torque | 4 in-lbs (0.458 Nm) |
| Mounting Surface | Flat, rigid mounting surface required for proper sealing and support |
| Surface Preparation | Mounting surface should be clean, dry, and free of burrs, scratches, or debris |

SCHEMATIC

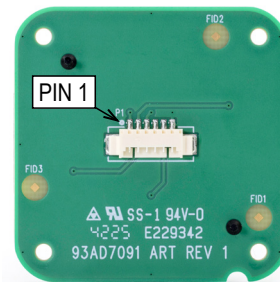
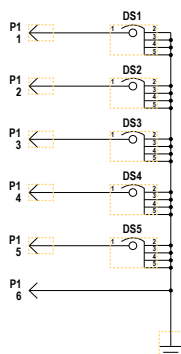

SPECIFICATIONS

Environmental Testing Standards

| | | |
|----------------------------------|--|--|
| Storage Temperature, High | +85 °C for 24 hrs | MIL-STD-810H Method 501.7, Procedure I |
| Storage Temperature, Low | -50 °C for 24 hrs | MIL-STD-810H Method 502.7, Procedure I |
| Thermal Shock | -50 °C to +85 °C, 24 cycles, 30 min dwell time, 1 hr 15 min stabilization | MIL-STD-810H Method 503.7, Procedure I-C |
| Altitude | 57 kPa for 1 hr (15,000 ft) | MIL-STD-810H Method 500.6, Procedure I |
| Solar Radiation | 10-day Actinic Effects hot-dry cycle | MIL-STD-810H Method 505.7, Procedure II |
| Random Vibration | Transportation random vibration profile, ~7.7 Grms over 10-2000 Hz, 3 hrs per axis across three mutually perpendicular axes | MIL-STD-810H Method 514.8, Procedure I |
| Functional Shock | 40 G, 11 ms saw-tooth pulse, 3 shocks in each direction across three mutually perpendicular axes | MIL-STD-810H Method 516.8, Procedure I |
| Humidity | 10 cycles, 24 hrs each, 30 °C to 60 °C at 95 ± 4% RH | MIL-STD-810H Method 507.6, Procedure II |
| Transit Drop | 26 drops from 48 in. across faces, edges, and corners when individually packaged | MIL-STD-810H Method 516.8, Procedure IV |
| Chemical Resistance | 8-hr exposure to cleaning compounds, antifreeze, rifle bore cleaner, DS-200, lubricating oil, hydraulic fluid, Dexron III, insect repellent, and isopropyl alcohol | MIL-STD-810H Method 504.3, Procedure II |
| Insulation Resistance | 500 ± 25 VDC for 120 sec, insulation resistance ≥1000 MΩ | MIL-STD-202 Method 302, Test Condition B |
| Dielectric Strength | 500 ± 25 Vrms for 60 sec, no flashover, no arcing, leakage current ≤1 mA | MIL-STD-202 Method 301 |
| Contact Capacitance | 1000 Hz, 0.6 Vrms for 60 seconds, contact capacitance ≤27 pF | MIL-STD-202 Method 305 |
| Dust-Tight | Fine talc dust in a circulating chamber with applied pressure differential for 8 hrs (button side when mounted) | IP6X |
| Immersion | 1 meter water immersion for 2 hrs (button side when mounted) | MIL-STD-810H Method 512.6, Procedure I |

ORDERING INFORMATION

